

## 产品展示——信天翁G50动力套件

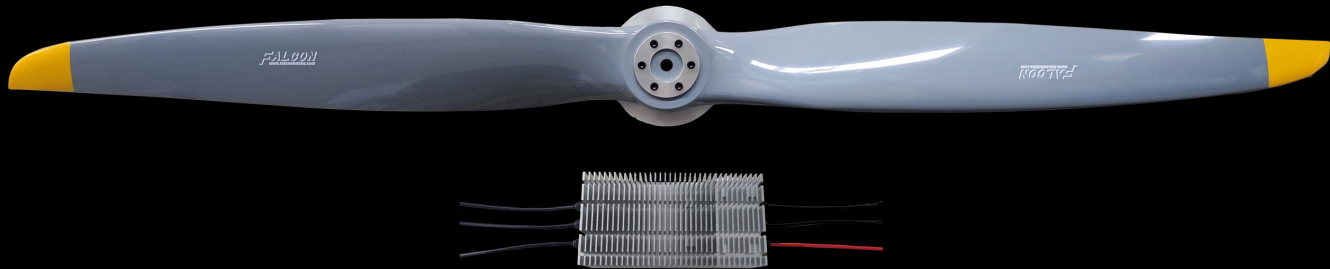

### 详细参数

电压范围 80~440Vdc

额定拉力 50kg

系统力效 6.3g/W

最大拉力 123kg

## 电压355V情况下

### 油门-拉力

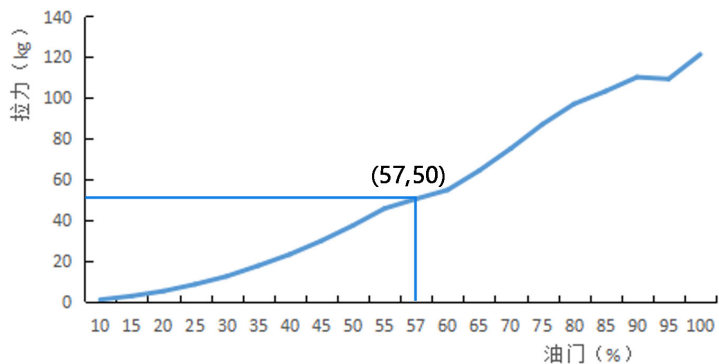

## 电压400V情况下

### 拉力-油门

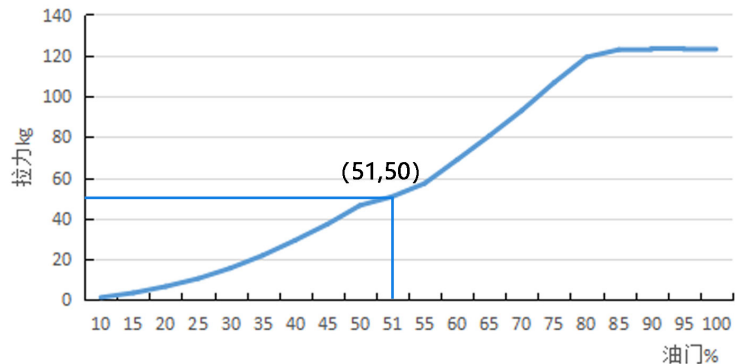

### 拉力-系统力效

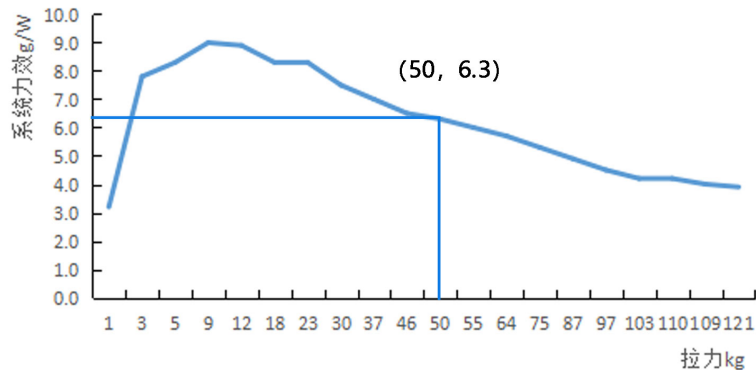

### 拉力-系统力效

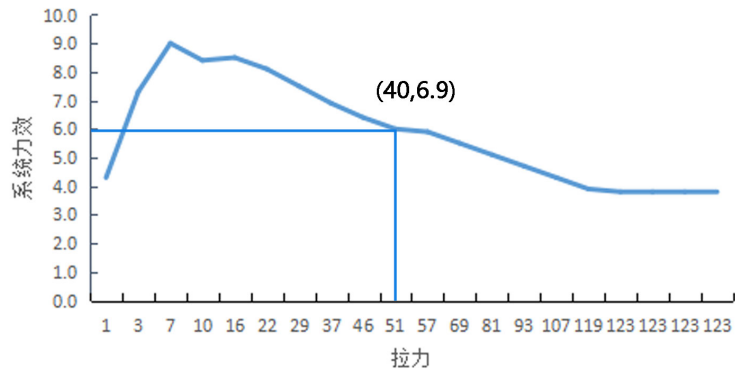

# 尺寸图

## 电调

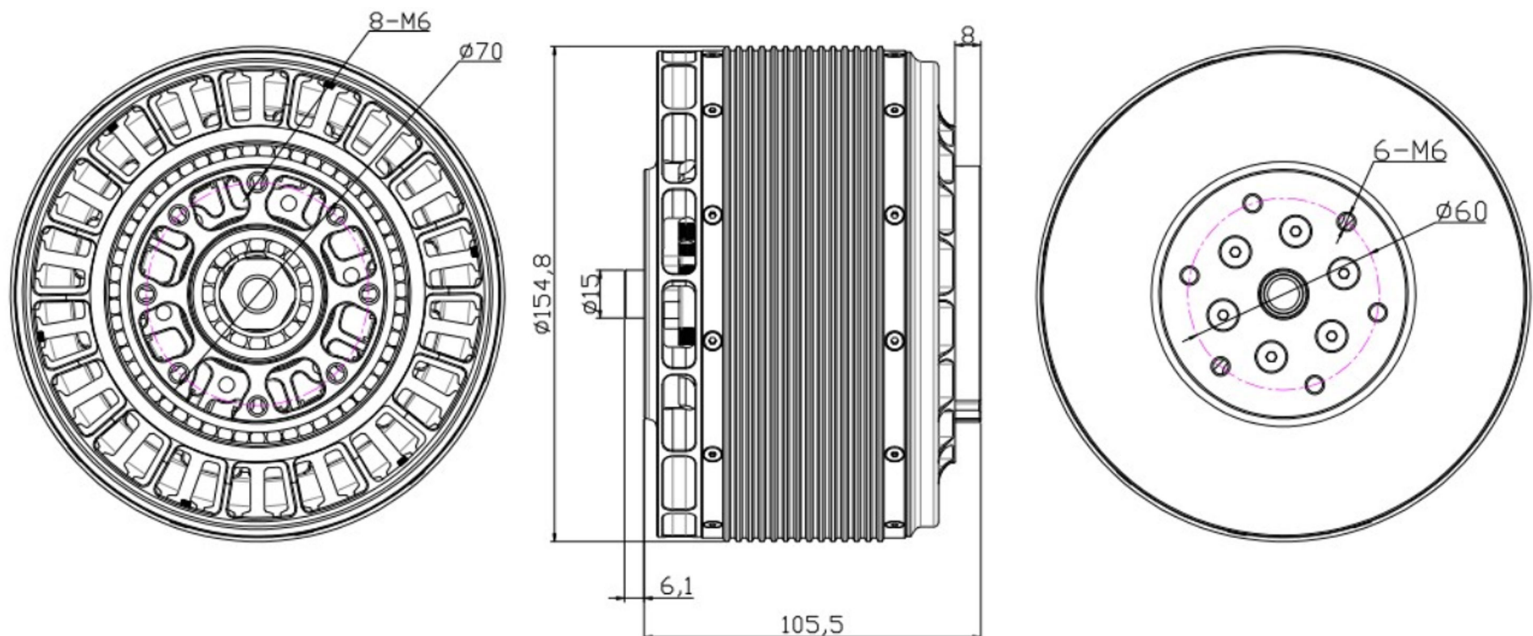
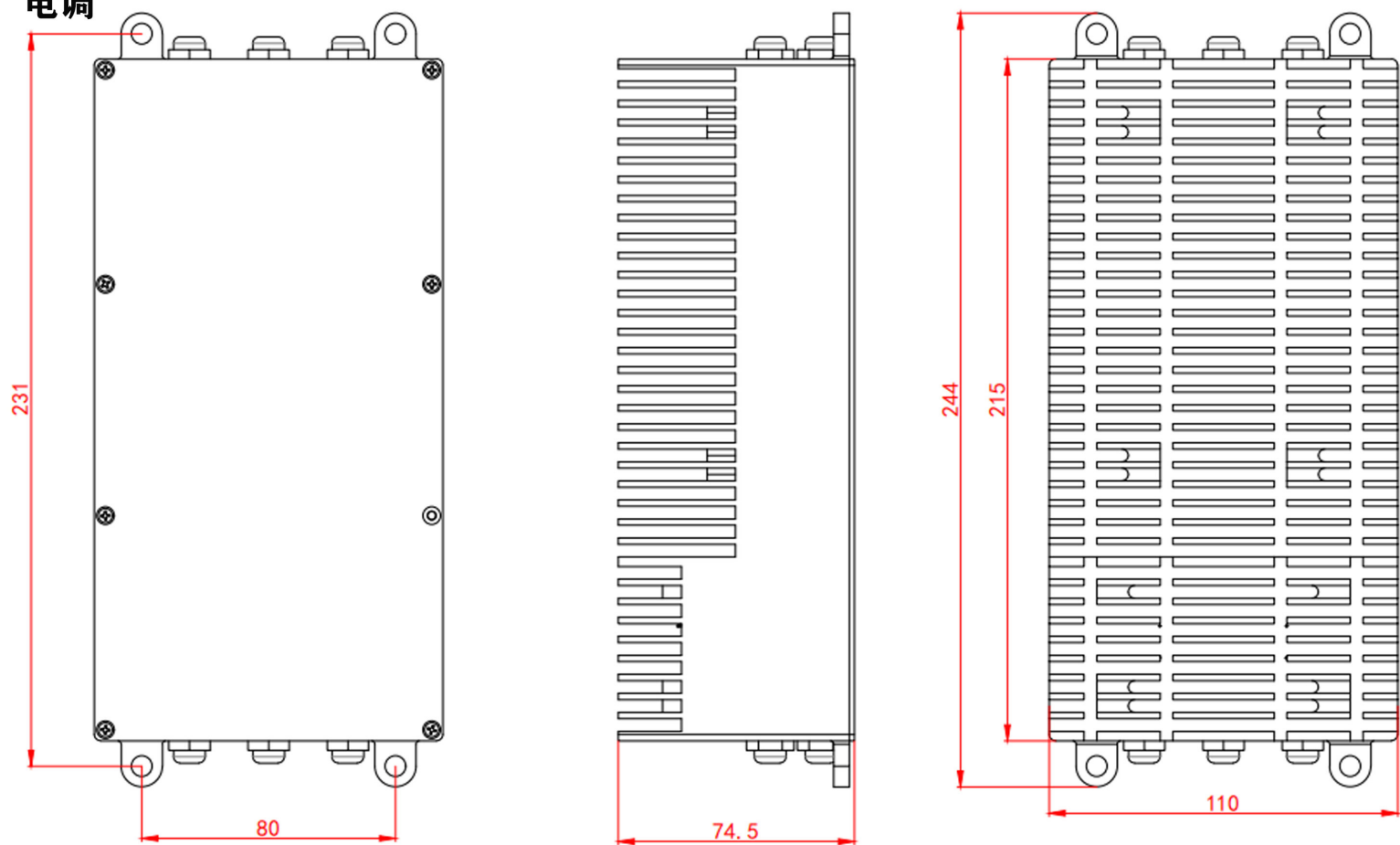

## 螺旋桨

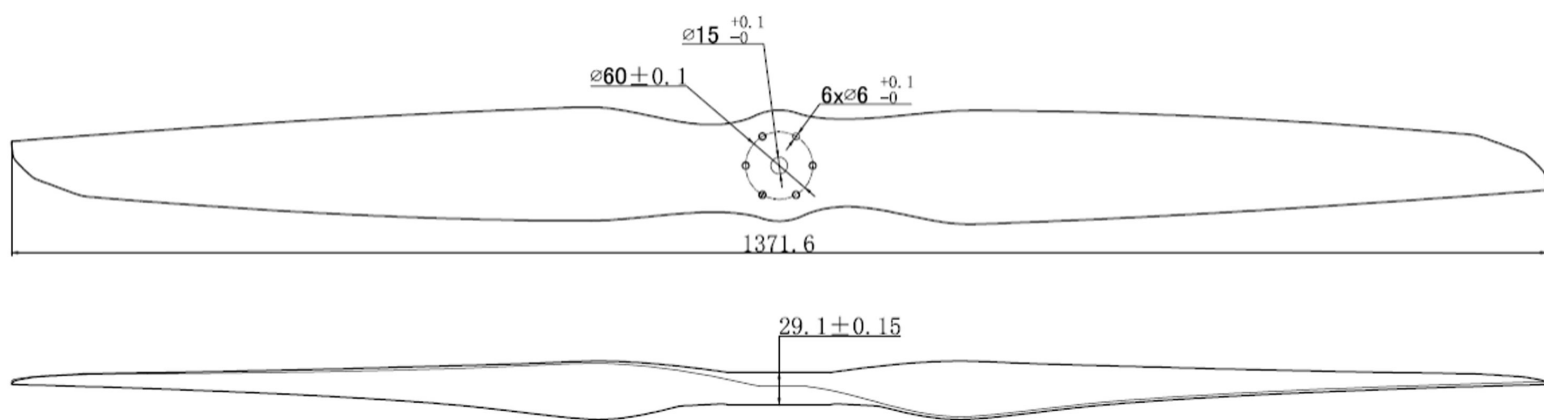

## 模块参数

### 电 调

型号	IG1-D3-060-080440-1
重量	1.5kg
外壳尺寸	244mm*110m75mm
电压范围	80~440Vdc
额定功率	9kw
峰值电流	60A
油门校准行程	支持
电源线	硅胶线-红/黑色-14AWG-37cm*2
输出线	硅胶线-黑色-14AWG-35cm*3
信号线	硅胶线-28AWG

### 电 机

型号	C14050
KV值	8rpm/v
额定功率	10kW
电压范围	80-440Vdc
重量	4.5kg
内阻	387mohm
磁钢极对数	15

### 螺旋桨

尺寸	54*24in
单支桨重量	830g

## 测试数据-355V

油门-%	PWM-us	拉力-g	扭矩-N*m	电压-V	电流-A	换相转数-RPM	总(电)功率-W	轴功率-W	电机效率-%	桨力效-g/W	系统力效-g/W
10	1185	988	0.7	353.5	0.9	360	311	26	8.2	38.5	3.2
15	1228	2816	1.9	353.1	1.0	570	360	111	30.8	25.4	7.8
20	1270	5218	3.3	353.1	1.8	750	625	262	42.0	19.9	8.3
25	1312	8557	5.2	352.9	2.7	960	949	526	55.4	16.3	9.0
30	1355	12475	7.6	353.9	4.0	1140	1405	912	64.9	13.7	8.9
35	1398	17672	11.0	352.6	6.0	1320	2126	1518	71.4	11.6	8.3
40	1440	23239	14.2	353.4	7.9	1530	2785	2272	81.6	10.2	8.3
45	1482	29880	18.2	353.8	11.3	1710	4005	3257	81.3	9.2	7.5
50	1525	37402	22.7	352.4	15.1	1920	5314	4556	85.7	8.2	7.0
55	1568	45741	27.6	352.3	19.9	2130	7018	6163	87.8	7.4	6.5
57	1586	50460	30.4	352.7	22.7	2220	8006	7063	88.2	7.1	6.3
60	1610	54849	33.1	352.5	25.8	2310	9077	8014	88.3	6.8	6.0
65	1652	64323	39.2	352.2	32.2	2460	11351	10093	88.9	6.4	5.7
70	1695	75156	45.9	351.9	40.5	2670	14245	12820	90.0	5.9	5.3
75	1738	87025	53.4	352.2	50.0	2820	17614	15758	89.5	5.5	4.9
80	1780	97016	61.4	351.5	61.7	3000	21691	19293	88.9	5.0	4.5
85	1822	103276	70.1	349.6	70.6	3060	24668	22029	89.3	4.7	4.2
90	1865	110204	70.0	351.1	75.1	3180	26354	23297	88.4	4.7	4.2
95	1908	109293	71.7	349.8	83.4	3220	29166	23883	81.9	4.6	4.0
100	1950	121328	78.7	344.9	89.1	3300	30738	26201	85.2	4.6	3.9

## 测试数据-400V

油门-%	PWM-us	拉力-g	扭矩-N*m	电压-V	电流-A	换相转数-RPM	总(电)功率-W	轴功率-W	电机效率-%	桨力效-g/W	系统力效-g/W
10	1185	1229	0.8	398.6	0.71	360	283	31	10.8	40.2	4.3
15	1228	3449	2.2	398.9	1.19	600	475	135	28.5	25.5	7.3
20	1270	6602	4.0	398.6	1.84	810	733	343	46.7	19.3	9
25	1312	10456	6.4	398.9	3.11	1050	1241	698	56.3	15	8.4
30	1355	15609	9.4	398.8	4.59	1260	1831	1238	67.6	12.6	8.5
35	1398	21863	13.2	398.8	6.76	1470	2696	2034	75.4	10.8	8.1
40	1440	29267	17.7	398.4	9.8	1710	3904	3170	81.2	9.2	7.5
45	1482	37197	22.5	398.4	13.59	1920	5414	4532	83.7	8.2	6.9
50	1525	46353	28.1	398.3	18.31	2130	7293	6263	85.9	7.4	6.4
51	1540	50720	30.9	398.8	21.11	2220	8419	7181	88.2	7.1	6
55	1568	57151	34.7	398.1	24.46	2340	9738	8496	87.2	6.7	5.9
60	1610	68726	41.8	397.7	31.53	2370	12540	10374	82.7	6.6	5.5
65	1652	80554	49.0	397.6	39.7	2670	15785	13706	86.8	5.9	5.1
70	1695	92909	57.9	397.5	50.06	2700	19899	16362	82.2	5.7	4.7
75	1738	106629	67.0	397	62.94	2970	24987	20835	83.4	5.1	4.3
80	1780	119111	78.4	395.5	78.15	3030	30908	25862	83.7	4.6	3.9
85	1822	122812	80.0	396.4	81.25	3060	32208	27908	86.7	4.4	3.8
90	1865	123331	79.8	396.1	80.99	3130	32080	28082	87.5	4.4	3.8
95	1908	123021	79.9	396.2	81.06	3230	32116	28103	87.5	4.4	3.8
100	1950	123344	80.1	396.3	81.65	3360	32358	28166	87	4.4	3.8



# 智鸥驱动 产品介绍

品类丰富 性能优良 技术先进 支持定制



[www.ig-driver.com](http://www.ig-driver.com)